

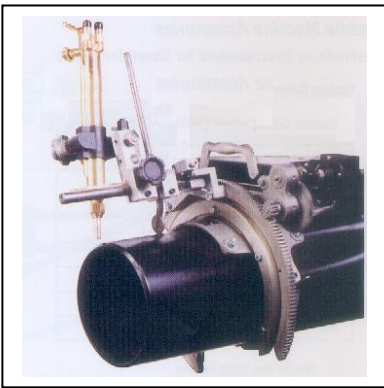

P. O. Box 472110, Tulsa, OK 74147-2110 USA
Toll Free: 800-725-7311
918-447-1288 Office
918-447-0188 Fax
www.mathey.com

Pro Model Torch Arm Parts and Operating Manual



Pro-Model with Out-Of-Round

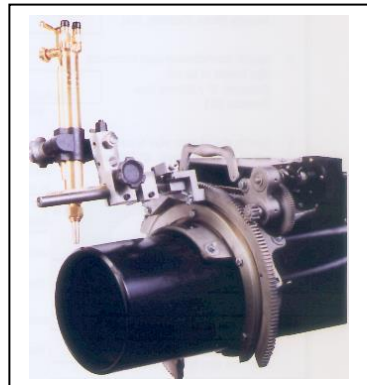

Rack Adjustable
Pro Model Torch Arm

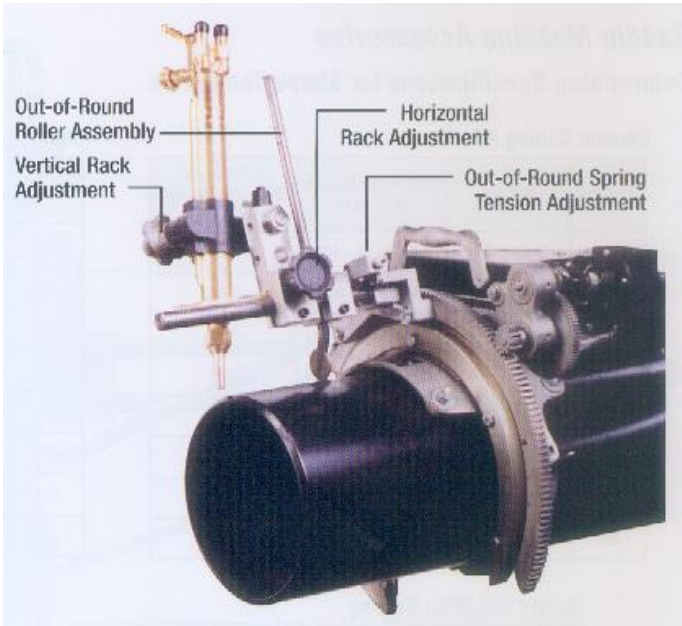

The Pro Model Torch Arm with Out-Of-Round feature is design for use with the Saddle Machine to compensate for oversize, undersize or out-of-round pipe. The Torch Arm permits the torch to be precisely adjusted horizontally and vertically by means of Racking Knobs. The Pro Model moves the torch radially to minimize notching of the pipe as it crosses the pipe weld seam or surface imperfection.

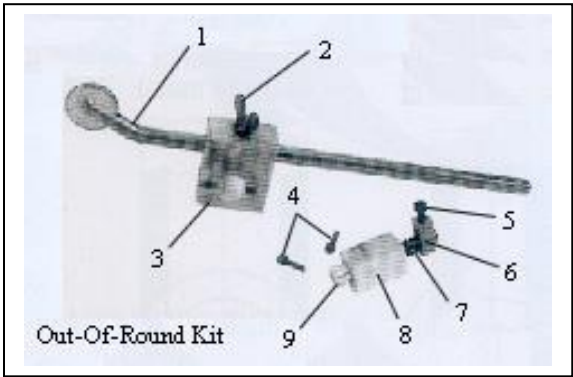

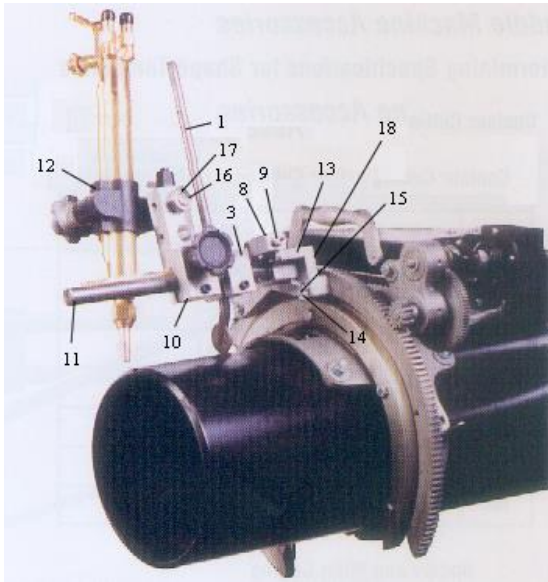

Installation of the Pro Model Torch Arm with Out-Of-Round Device to the Saddle Machine PN: 03-0209-000

1. Remove the current torch arm.
2. Move the Out-of-Round Roller Assembly (1) to its highest position and tighten the Wing Screw (2) to hold it in place.
3. Adjust the Spring Tensioning screw (9) so that there is $3/16'' - 1/4''$ space between Spring Housing (8) and Spring Tensioning Nut (9).

Note: No other adjustment of the Spring Tensioning Nut (9) is necessary, unless you want to restrict the radial movement of the torch.

4. Insert the Mounting Block (13) on to the Studs (15) on the Ring Gear of the Saddle Machine.
5. Install the Wing Nuts (14) on the Studs (15).
6. Loosen Wing Screw (2), let the Out-of-Round Roller Assembly (1) come to rest on top of the pipe and retighten the Wing Screw.
7. Install the plasma or oxy/fuel torch into Torch Holder (12).

Note: If it is required that the torch be rack adjustable upward and downward a 32 pitch rack must be ordered for the torch.

Note: The Torch Holder is also available with a pinion for a metric torch rack.

Customer Supplied Torch Holder

The Pro Model can be used with customer supplied torch holders having a 5/8" or 3/4" Stud.

- A. If the Pro Model Torch Holder is to be used with a customer supplied torch holder, remove Hex Nut (17).
 - B. Remove the torch support (16).
 - C. Move the Split bronze bushing and thumbscrew to the desired Hole.
 - D. Install the customer supplied torch holder.
8. With a 4mm Allen wrench tighten the 2 Allen Head Cap Screws on the Torch Holder to hold the torch in position.
 9. Adjust the torch to pipe height per the torch manufacturer's instructions.
 10. Rotate the torch around the pipe to see if the Roller of the Roller Rod Assembly is leaving the pipe.
 11. Adjust the Roller Rod Assembly as needed so the Roller Rod Assembly stays in contact with the pipe.
 12. The Machine is now ready for operation.

Installation of the Pro Model Torch Arm to the Saddle Machine

PN: 03-0209-001

1. Remove the current torch arm.
2. Insert the Mounting Block (13) on to the Studs (15) on the Ring Gear of the Saddle Machine.
3. Install the Wing Nuts (14) on the Studs (15).
4. Install the plasma or oxy/fuel torch into Torch Holder (12)

Note: If it is required that the torch be rack adjustable upward and downward a 32 pitch rack must be ordered for the torch.

Note: The Torch Holder is also available with a pinion for a metric torch rack.

Customer Supplied Torch Holder

The Pro Model can be used with customer supplied torch holders having a 5/8" or 3/4" Stud.

- A. If the Pro Model Torch Holder is to be used with a customer supplied torch holder, remove Hex Nut (17).
 - B. Remove the torch support (16).
 - C. Move the Split bronze bushing and thumbscrew to the desired Hole.
 - D. Install the customer supplied torch holder.
5. With a 4mm Allen wrench tighten the 2 Allen Head Cap Screws on the Torch Holder to hold the torch in position.
 6. Adjust the torch to pipe height per the torch manufacturer's instructions.
 12. The Machine is now ready for operation.

Installation of the Out-Of-Round Kit

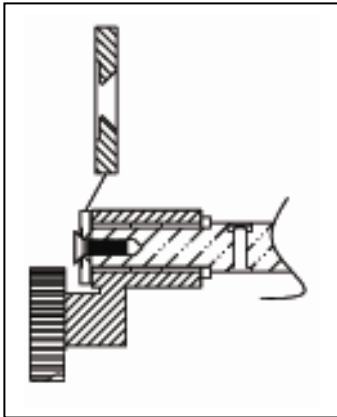

Position A - If the unit is to be used as a Pro Model Torch Arm with Out-Of-Round Device, position of the washer so that the countersink faces inward.

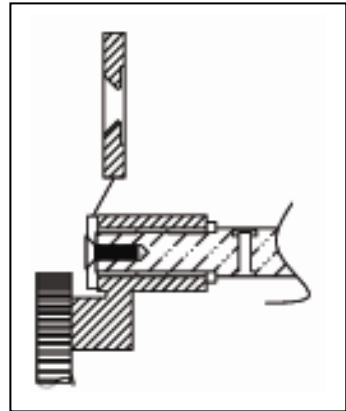

Position B - If the unit is to be used as a Rack Adjustable Pro Model Torch Arm, position the washer so that the countersink faces outward.

1. Remove the Torch Block (10) from the Torch Arm (11).
2. Mount the Spring Housing (8) to Mounting Block (13) using Allen Head Cap Screws (4).

3. Mount the Spring Block to the torch using the provided Allen Head Cap Screw.
4. Remove the Flat head Allen Screw from the Locking End Cap (18).
5. Rotate washer as shown in Position A.
6. Insert the Flat head Allen Screw into washer and screw into the Torch Arm (11) and tighten.
7. Rotate the Torch Arm (11) and install the Spring (7) into the Spring Housing (8).
8. Use the Torch Arm (11) to compress the Spring (7) enough to insert the Spring Guide (not shown) into the Spring (7).
9. Screw the spring tension nut (9) on to the Spring Guide.
10. Install the Out-of-Round Roller Assembly Block (3) on to the torch Arm (11).
11. Follow the procedure for “Installation of the Pro Model Torch Arm with Out-Of-Round Device to the Saddle Machine.”

Warranty

If any merchandise sold hereunder (except merchandise manufactured by other persons or firms) by Mathey Dearman, Inc. (the “Company”) is not in accordance with specifications shown on the order within customarily accepted tolerances, or is defective on account of workmanship or material, and if such merchandise is returned at the customer’s expense and rise, to the Company’s manufacturing facility (or at the Company’s option, is returned to a repair facility authorized by the Company), within ninety (90) days after the Company’s date of shipment thereof, the Company will, at its option, replace or repair the merchandise. This agreement, however, is upon the conditions: (A) that the customer promptly notifies the Company in writing of any claim under this agreement, setting forth in detail any such claimed defect. (B) That the Company be afforded a reasonable opportunity to examine the merchandise and to investigate the claimed defect at the Company’s manufacturing facility or at an authorized repair facility, the Company shall not be, in any event, liable for damages beyond the price paid by the customer for such defective merchandise; specifically but without limitation, the Company may fulfill its obligations under this Agreement by tendering such purchase price at any time. THE COMPANY SHALL NOT BE LIABLE FOR CONSEQUENTIAL, INCIDENTAL, PUNITIVE, OR EXEMPLARY DAMAGES. This agreement does not obligate the Company to bear any transportation charges in connection with the replacement or the repair of defective merchandise. As to any item manufactured by other persons or firms, the Company agrees to present a request for adjustment for repair to such manufacturer, and the customer agrees that the liability of the Company shall not exceed any adjustment with respect to which such manufacturer accepts responsibility. THE ABOVE AGREEMENT IS IN LIEU OF ALL WARRANTIES, EXPRESSED OR IMPLIED AND IT IS AGREED THAT THERE IS NO EXPRESSED OR IMPLIED WARRANTY BY THE COMPANY AS TO THE FITNESS, MERCHANTABILITY CAPACITY, OR EFFICIENCY OF ANY MERCHANDISE SOLD, AND THAT THERE ARE NO ORAL OR WRITTEN EXPRESSED OR IMPLIED WARRANTIES MADE IN CONNECTION WITH ANY SALE BY THE COMPANY. No modification or addition to this agreement, either before or after the contract of sale, shall be made except on written authority of the President or Vice President of the Company.