



E-Z PIPECUT AUTO

Automatic chain driven portable oxy-fuel cutting machine

The Mathey Dearman E-Z Pipecut Auto is the powered version of the E-Z Pipecut Manual. Once the speed is set correctly to the wall thickness of the pipe the machine can be driven around the pipe with a speed adjustable remote control.

The E-Z Pipecut Auto will cut and bevel the pipe without the need for intervention from the operator.

The E-Z Pipecut Auto portable oxy-fuel cutting machine can also be used for cutting exotic materials such as stainless steel, by converting from oxy-fuel to a plasma system (plasma torch holder available on request).

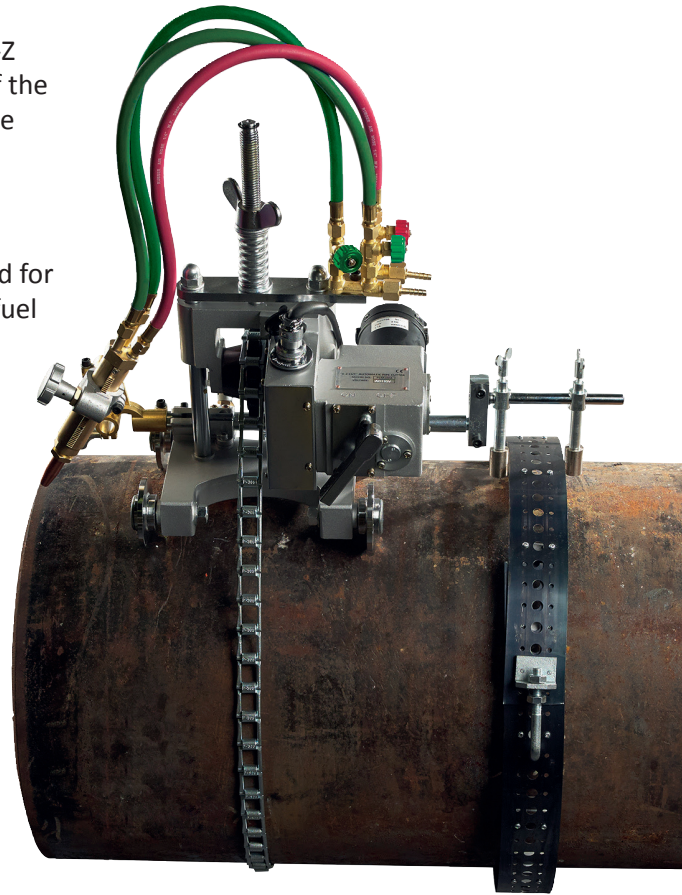
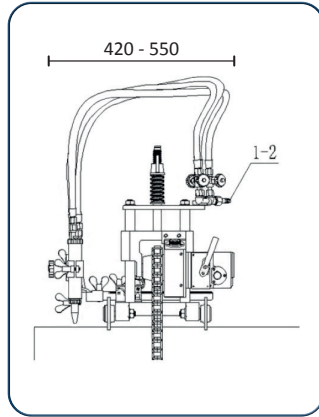
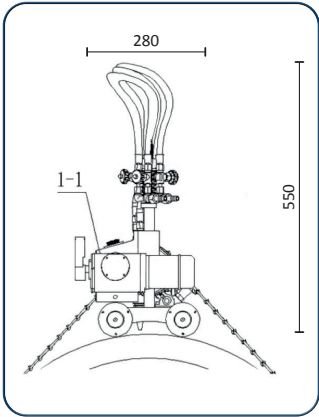

Guide band

For guaranteed square cuts and bevels on pipe diameters larger than 600 mm, using the optional guide band system to suit the relevant pipe size(s) is recommended.

Remote control



*** Outside the USA the green hoses will be blue**

E-Z Pipecut Auto includes:

- Pipe cutting machine E-Z Pipecut Auto
- Standard chain for cutting pipe diameter of 114 - 600 mm
- Connecting lead (5 m)
- Remote control
- Transformer 110v - 220v
- Operation instructions

Technical specification

| | |
|--------------------|--|
| Part No | EZPCA1: 110v / EZPCA2: 220v |
| Power supply | 230v / 110v / 50 - 60Hz |
| Pipe diameter | Up to 600 mm (in standard configuration) |
| Wall thickness | 5 - 50 mm |
| Torch | Universal nozzle-mix torch suitable for all nozzle-mix cutting nozzle (nozzles not included) |
| Cut/bevel angle | Variable up to 45° |
| Vertical torch +/- | 50 mm |
| Lateral torch +/- | 100 mm |
| Track width | 230 mm |
| Cutting speed | 50 - 1,150 mm/min |
| Weight | 16.00 kg / 36 lbs. |
| Dimensions | 420 (l) x 280 (w) x 550 (h) mm |



www.MATHEY.com