

Mathey Dearman's E-Z Pipecut portable oxy-fuel cutting and bevelling chain driven machines are the economical solution for cutting and bevelling pipe with wall thickness 5 mm up to 50 mm.

The Mathey Dearman E-Z Pipecut Manual is small and compact, strong and reliable, used by contractors, welders and pipe fitters, equally on-site or in the workshop.

The E-Z Pipecut Manual portable is a straight forward hand operated compact chain driven pipe cutting machine that provides a smooth, accurate cutting action by incorporating a low gear ratio and worm wheel drive.

The machine also features a quick-release clutch, that allows the operator to disengage the chain from the drive cog for rapid set up and positioning.

The bevelling head angle (up to 45°) can be set quickly and accurately by scale on a rack and pinion.

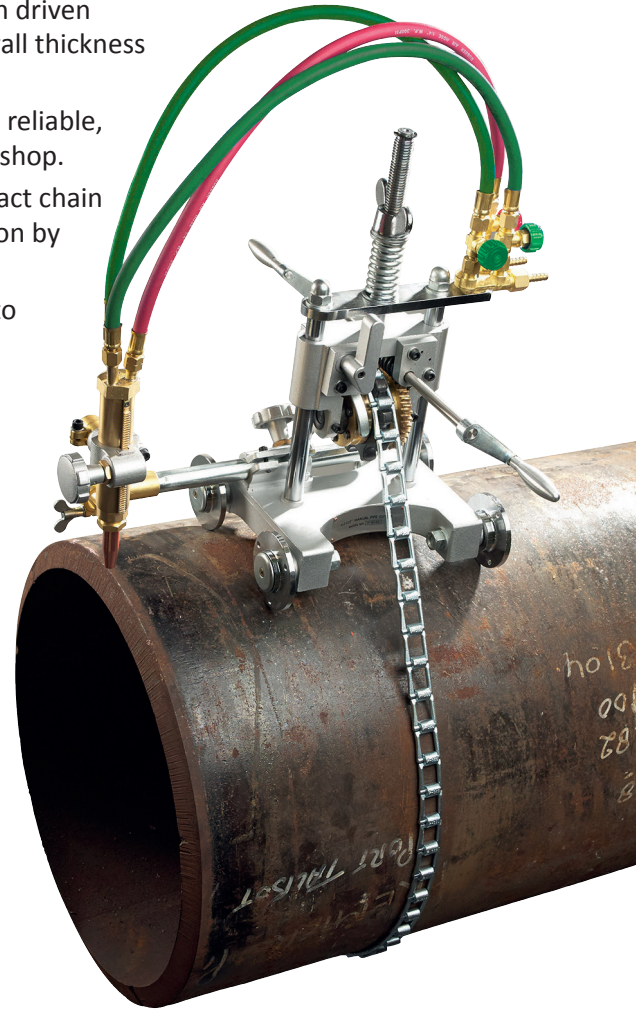

\* Outside the USA the green hoses will be blue

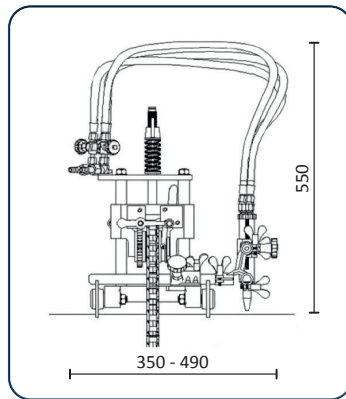
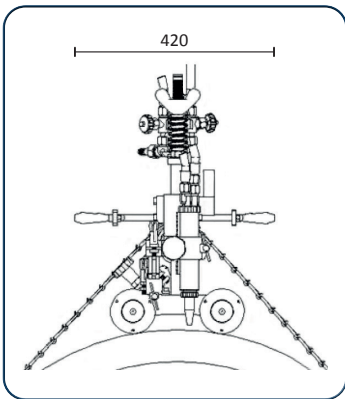

### Guide band

For guaranteed square cuts and bevelling on pipe diameters larger than 600 mm, using the optional guide band system to suit the relevant pipe size(s) is recommended.

### E-Z Pipecut Manual includes:

- Cutting machine E-Z Pipecut manual
- Standard chain for cutting pipe diameter of 4½" - 24" / 114 - 600 mm
- Operation instructions

### Technical specification

Part No	EZPCM
Power supply	Manual driven unit
Pipe diameter	Up to 600 mm (in standard configuration)
Wall thickness	5 - 50 mm
Torch	Universal nozzle-mix torch suitable for all nozzle-mix cutting nozzle (nozzles not included)
Cut/bevel angle	Variable up to 45°
Vertical torch +/-	50 mm
Lateral torch +/-	100 mm
Track width	230 mm
Weight	8.50 kg / 18.70 lbs.
Dimensions	350 (l) x 420 (w) x 550 (h) mm